

# Arvin's DCF Clock

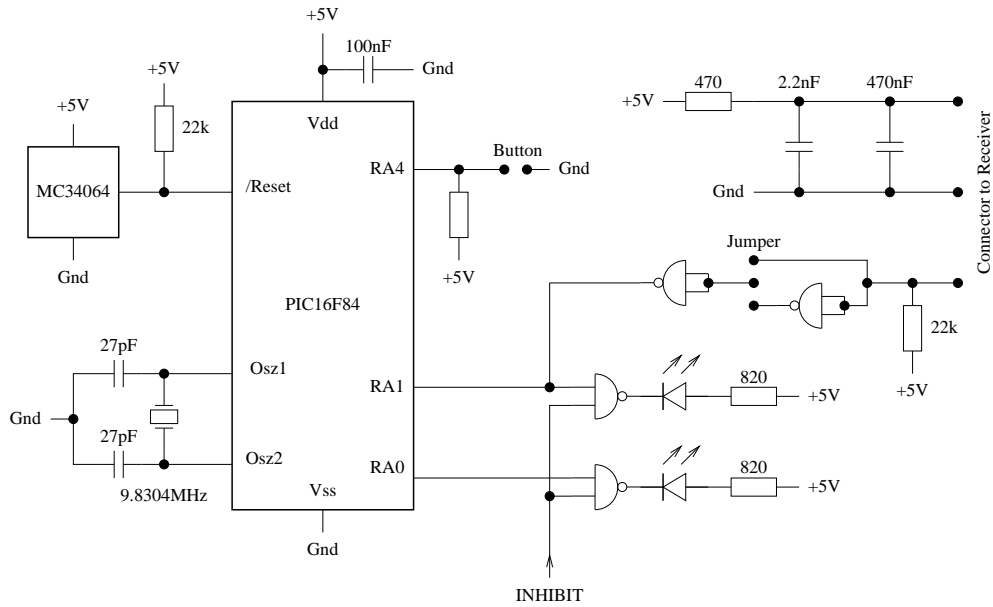

Figure 1: Circuit Diagram of Main Stuff

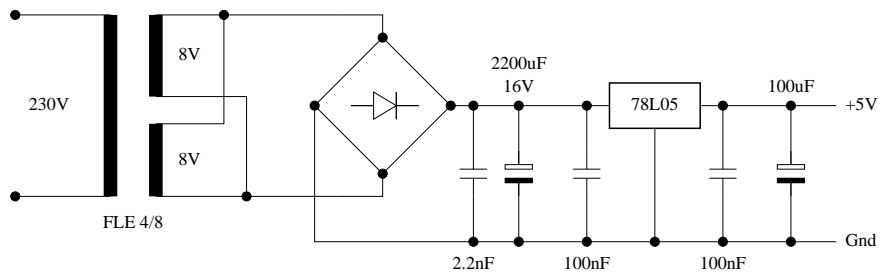

Figure 2: Circuit Diagram of Power Supply

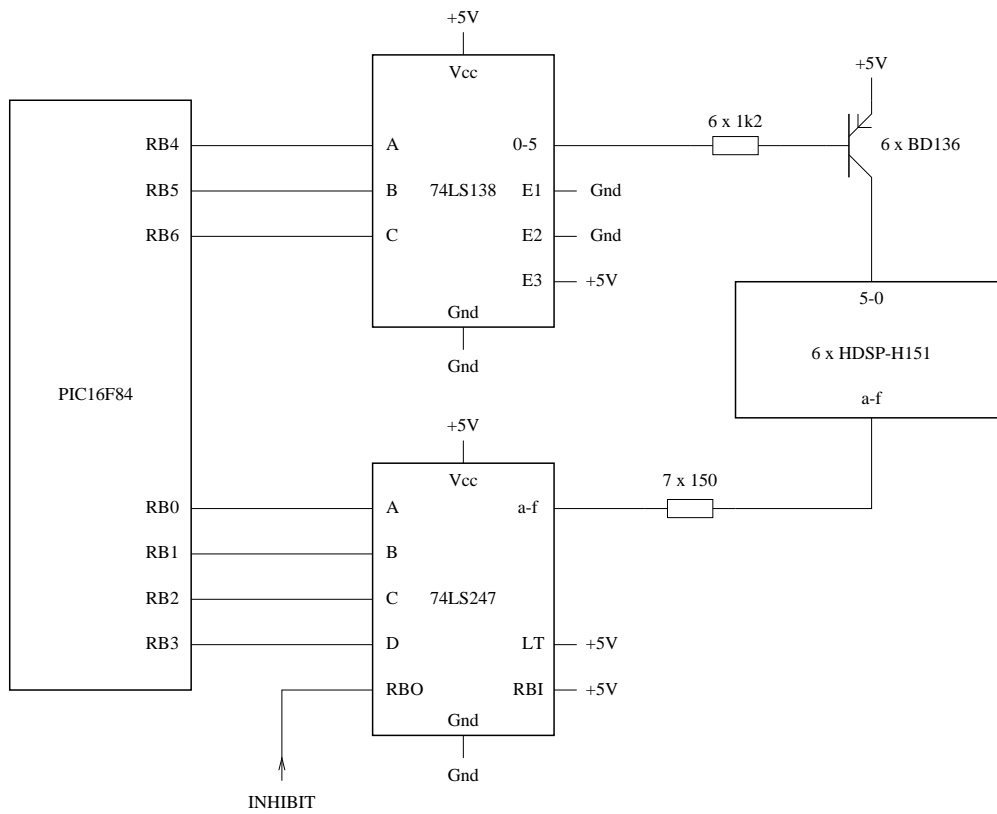

Figure 3: Circuit Diagram of Display Stuff

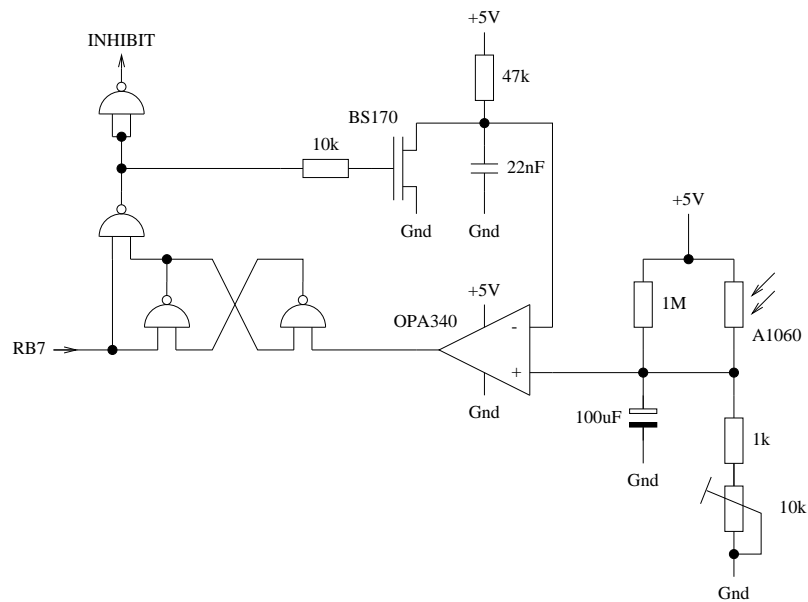

Figure 4: Circuit Diagram of Brightness Control

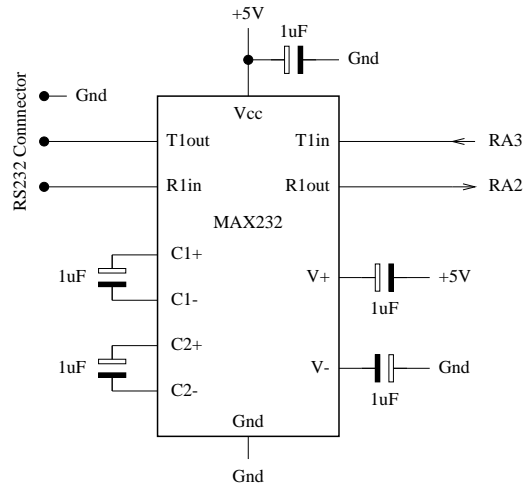

Figure 5: Circuit Diagram of RS232 Interface

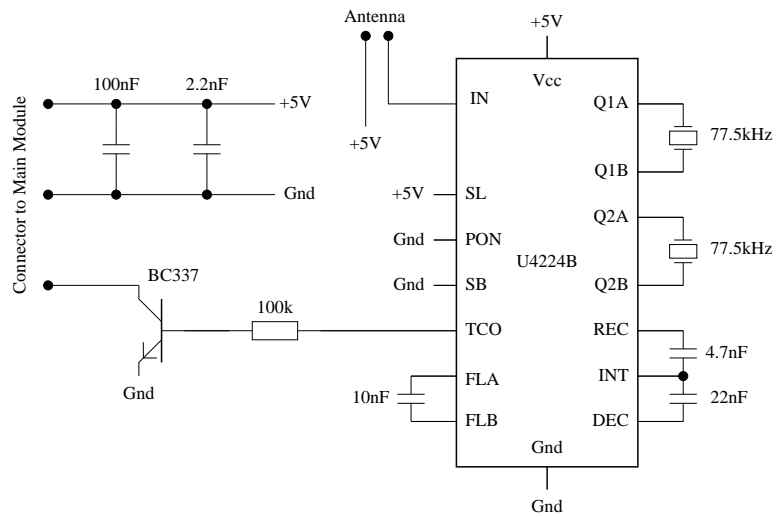

Figure 6: Circuit Diagram of Receiver

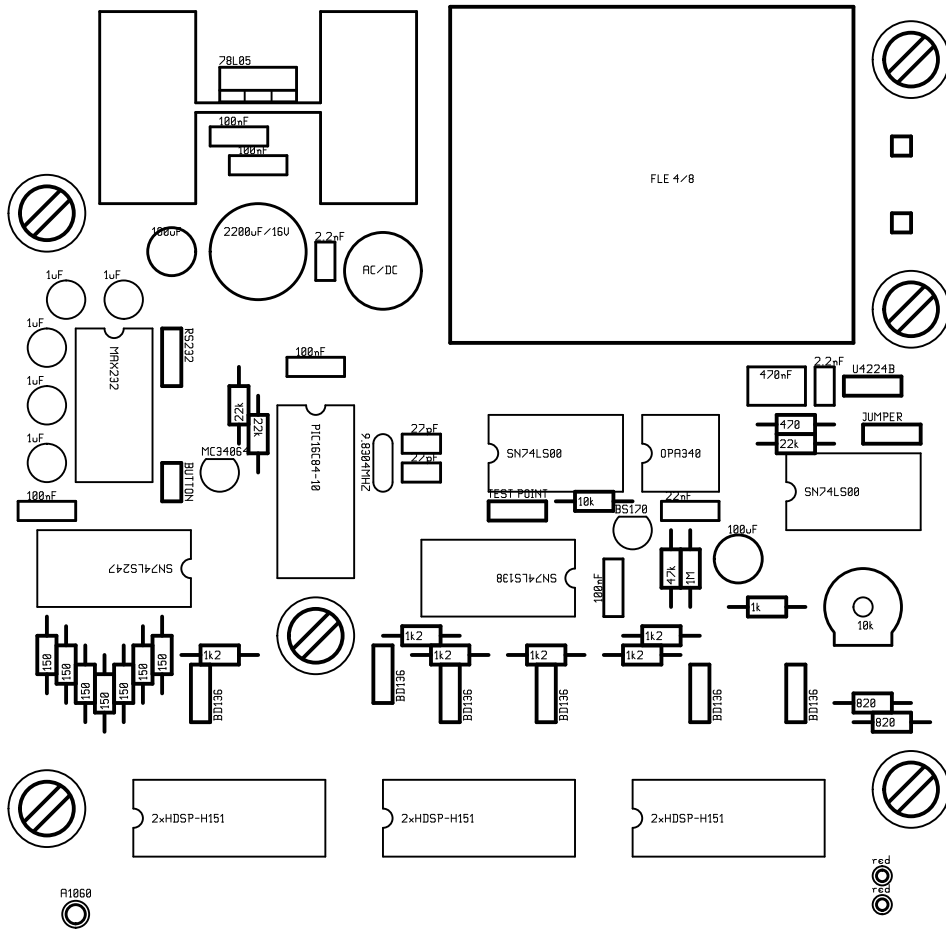

Figure 7: Printed Circuit Board of Main Module (Silk)

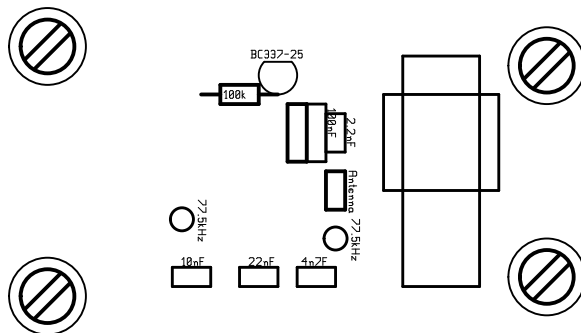

Figure 8: Printed Circuit Board of Receiver (Silk)

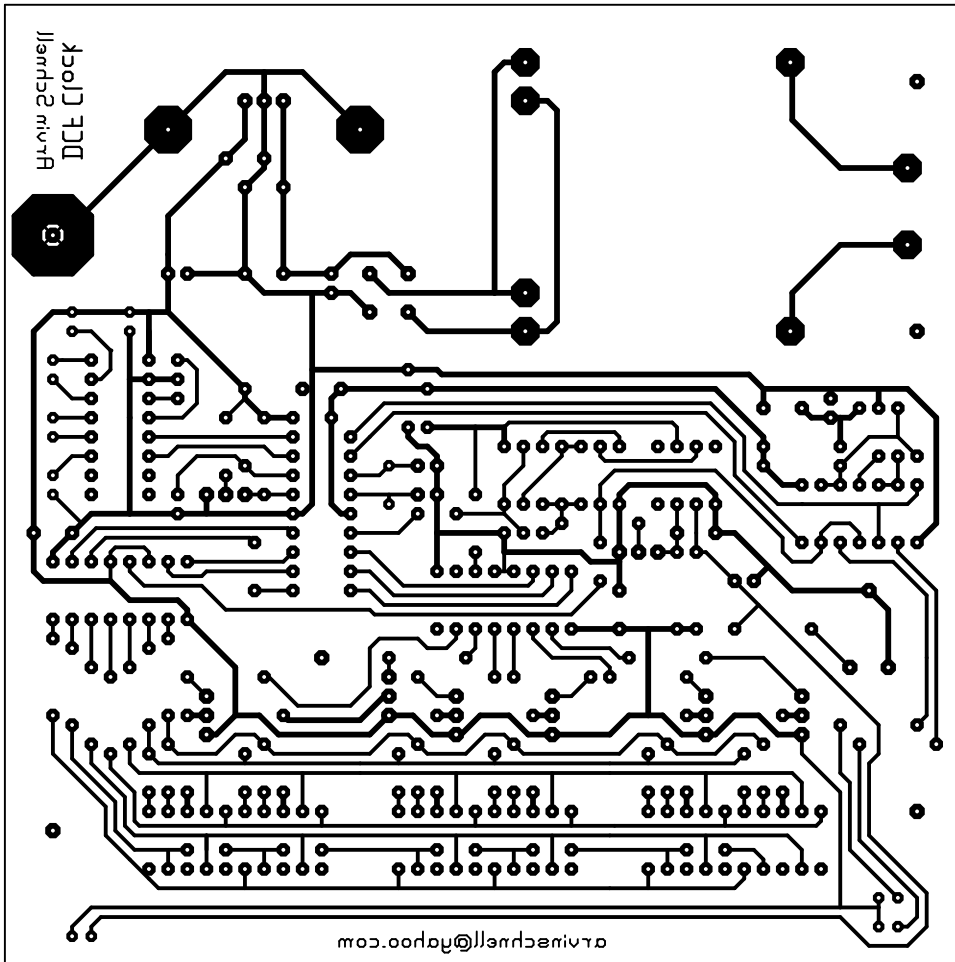

Figure 9: Printed Circuit Board of Main Module (Solder)

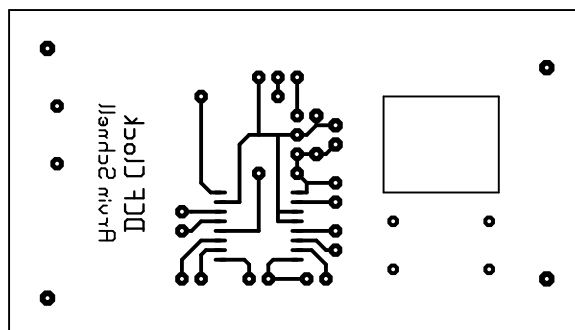

Figure 10: Printed Circuit Board of Receiver (Solder)